



SJ 3173-60 SR

SJ 3173-90 SR

Brugervejledning

Gør en forskel i dit køkken med vores emhætter.
Emhætter spiller en vigtig rolle i at holde dit køkken friskt;
Du kan nyde at lave mad når som helst.

Tak fordi du har købt denne højkvalitets emhætte hos os.
Vores politik er løbende udvikling og forbedring.
Nøjagtigheden af billeder og specifikationer er ikke garanteret.
Når du bruger enheden for første gang, skal du fjerne al
emballage og beskyttere.
Installationen skal udføres af sagkyndigt personale.
Producenten påtager sig intet ansvar for skader som følge af
forkert brug eller installation. Læs venligst denne vejledning
omhyggeligt og gem den til fremtidig brug.

INDHOLD

1 VIGTIG SIKKERHEDSMEDDELELSE

2 FUNKTION

3 SIKKERHEDSADVARSEL

4 PRODUKT INTRODUKTION OG TEKNISK INFORMATION

5 MONTERING & INSTALLATION

6 PRODUKT BRUG

7 VEDLIGEHOLDELSE OG RENGØRING

1 VIGTIG SIKKERHEDSMEDDELELSE

Kære kunde, tak fordi du valgte vores emhætte.

Denne brugervejledning beskriver den korrekte installation og brug af din emhætte.

- Selvom du er bekendt med produktet, bedes du læse brugervejledningen omhyggeligt, før du bruger den.
- Manualen skal opbevares.
- Installationsarbejde skal udføres af en kvalificeret og kompetent montør.
- Producenten påtager sig intet ansvar for skader eller personskader, der skyldes manglende overholdelse af følgende regler.
- Emhætten bruges ved 220/240v, 50-60 Hz.
- Bemærk venligst, at denne vejledning også kan gælde for andre modeller.

2 FUNKTION

- Der er brugt materialer af høj kvalitet i emhætten og der er lavet et moderne design.
- Udstyret med en kraftig støjsvag elmotor, som producerer et stærkt sug med lavt støjniveau.

3 SIKKERHED SADVARSEL

- Arbejdsspænding 220/240v
- Lad aldrig børn betjene emhætten.
- Emhætten er kun til hjemmebrug, ikke egnet til industrikøkkener.
- Bed venligst den tekniske person om at udføre installationen.
- For at opnå den bedste effekt bør emhætter placeres i en afstand på 45-65 cm fra kogepladen.
- Brug ikke din emhætte uden fedtfiltere, eller hvis filterene er meget olierede.
- Fjern ikke filteret, mens emhætten er i drift.
- Efterlad ikke kogegej uden opsyn, mens de er i brug, da overophedede fedtstoffer eller olie kan antændes og stoffer i fedtfilteret kan antændes og forårsage brand.
- Efterlad aldrig åben ild under emhætten.
- Hvis emhætten ikke rengøres med jævne mellemrum, kan der være risiko for forbrændinger i emhætten.
- Emhætten skal tændes efter at have sat gryder eller pander på komfuret.
- For at rense køkkenluften grundigt for lugt, bør emhætten betjenes 15 minutter efter tilberedning.
- For at holde emhætten og fedtfilteret i god stand, skal de rengøres regelmæssigt.
- Sluk for strømmen fra hovedforsyningen før rengøring.
- Rengør din emhætte i henhold til brugermanualen og beskyt den mod farer.
- Hvis der er en funktionsfejl i enheden, bedes du kontakte serviceafdelingen.

4 PRODUKT INTRODUKTION OG TEKNISK INFORMATION

- Ⓐ SKORSTEN
- Ⓑ EMHÆTTE
- Ⓒ KONTROL PANEL

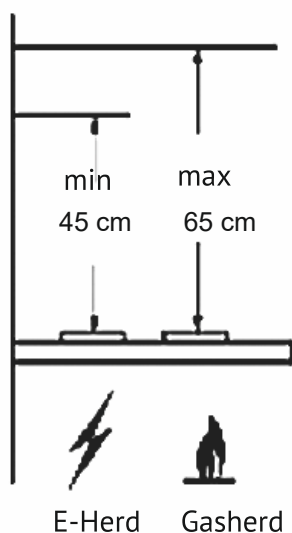
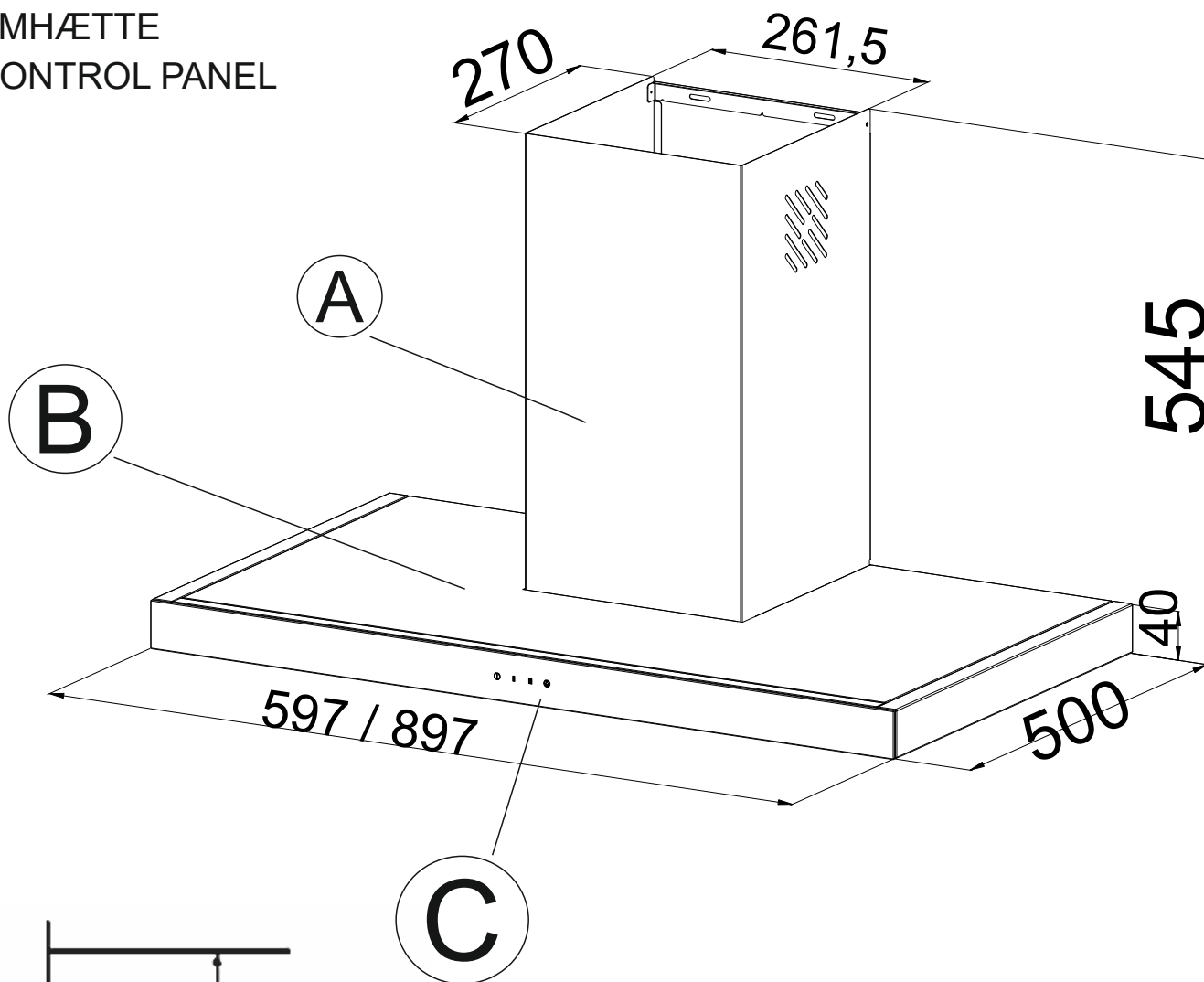

BREDDE	597/897 mm
DYBDE	500mm
HØJDE	545 mm
SPÆNDING	220-240V, 50-60 Hz
KAPACITET	750 m3/h
TRIN	3
EFFEKT	210 W
LYS EFFEKT	2X2 W
LUFTUDGANG	150/120 mm

5 MONTERING & INSTALLATION

- For at opnå den bedste effekt bør enhættet placeres i en afstand på 45-65 cm fra kogepladen.
- Inden du starter installationen, skal du følge instruktionerne herunder:
- Kontroller, om det købte produkt er af passende størrelse til det valgte installationsområde.
- Fjern eventuelt kulfilteret. Denne/disse bør kun monteres, hvis du ønsker at bruge enhættet til recirkulation.
- Kontroller, af forsendelses mæssige årsager, at der ikke er skader og alle dele er i kassen.
- Væggen/loftet skal være stærkt nok til at bære enhættens vægt.

5 MONTERING & INSTALLATION

Produktplacering: Højden mellem den nederste flade af emhætten og den øverste overflade af komfuret bør ikke være mindre end 45 cm.





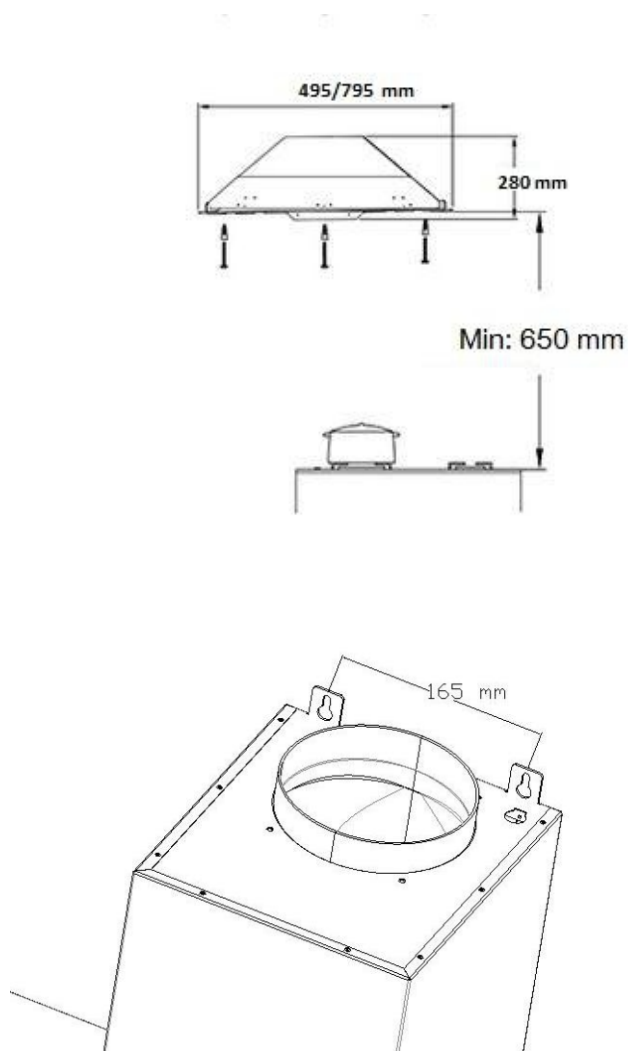

Forberedelser til installation af produktet: Følgende oplysninger er nødvendige for at gøre din placering egnet til dit boligareal.

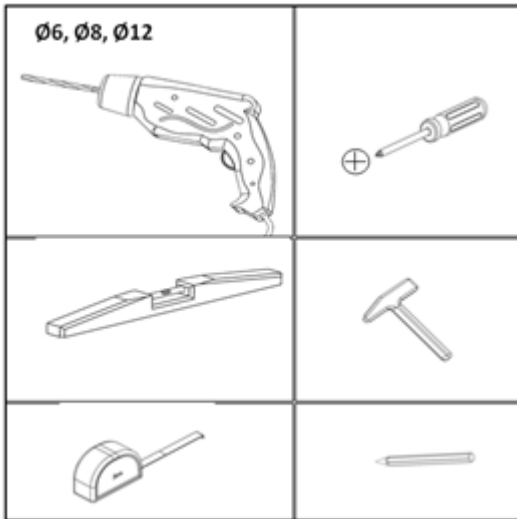
Montering af produktet: Fastgør emhætten til væggen med rawplugs og skruer.



5 MONTERING & INSTALLATION



	Ø8x40	4x
	Ø5x40	4x
	Ø7	4x
	Ø3.9x19	6x
		1x
		1x
	120	1X

6 PRODUKT BRUG

- Vi anbefaler at tænde emhætten 5-10 min før madlavning og lade emhætten køre 15 min efter endt madlavning.

- For at vedligeholde en regelmæssig ydeevne er det vigtigt at emhætten bliver vedligeholdt og rengjort og installationen har fast rørføring uden skarpe bøjninger.

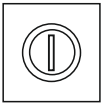
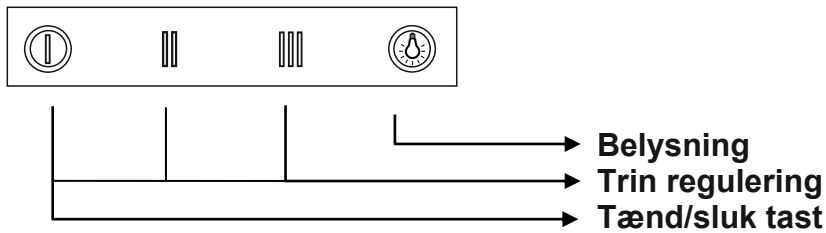

Tænd/sluk tast: Hvis du trykker på denne knap, starter motoren på trin 1. Tryk på denne knap for at slukke for produktet.



Lampe : Denne knap tænder og slukker lyset..



Trin regulering: Du kan vælge i mellem 3 hastigheder via disse 3 taster.

Fedfilter advarsel: Efter 30 timers drift vil der ses et "F" på displayet.

Det betyder at dine fedtfilter skal rengøres.

For at fjerne symbolet efter rengøringen skal motor være slukket og du skal du holde "-" knappen i bund indtil du ser et "E" på displayet.

Kulfilter advarsel: Efter 300 timers drift vil der ses et "C" på displayet.

Det betyder at dine kulfilter skal skiftes eller rengøres/rens.

For at fjerne symbolet efter rengøringen skal motor være slukket og du skal du holde "+" knappen i bund indtil du ser et "E" på displayet.

7 VEDLIGEHOJDELSE OG RENGØRING FORSIGTIG

VEDLIGEHOJDELSE OG RENGØRING

Inden der udføres nogen form for vedligeholdelse og rengøring skal emhætten afbrydes for strøm. Emhætten bør rengøres regelmæssigt.

Emhætten kan rengøres med en varm fugtig klud.

Brug ikke rengøringsmidler med slibemiddel, da det kan ridse lakken/overfladen. Brug venligst ikke ætsende rengøringsmidler, da du kan beskadige enheden.

Hold motoren og andre reservedele væk fra vand, da det kan beskadige enheden.

FEDTFILTER

Opfanger madpartikler. fedtfilteret skal rengøres en gang om måneden med ikke-aggressive rengøringsmidler i hånden eller i opvaskemaskinen, som skal indstilles til lav temperatur og kort cyklus.

Farven på fedtfilteret i opvaskemaskinen kan ændre sig lidt, men dette påvirker ikke dets filtreringsevne. Brug ikke ætsende rengøringsmidler.

Træk i det fjederbelastede udløser håndtag for at fjerne fedtfilteret.

KULFILTER

Man skal bruge emhætten med kulfiltre, hvis man ikke kan føre luften ud af boligen vha. en aftrækskanal. Kulfiltre er ekstra tilbehør, som man kan købe hos forhandlere. Ved at bruge denne løsning renses man lugten igennem kulfilteret. Bemærk at fedtfilteret stadig skal bruges til at opfange fedtet i madosen. Det er vigtigt at emhætten kan smide samme mængde luft ind tilbage i køkkenet som den suger. Ellers vil man kunne oplevetryktab og dermed mere støj og mindre sugsevne. F.eks. hvis emhætten smider luften tilbage ind bag et krydderiskab anbefales der, at der er lufttilførsel derfra ind i køkkenet. Vi anbefaler man sætter en aftrækskanal på som kan føre luften bag skabet og evt. op dertil hvor luften smides ind i køkkenet, for at undgå fugt bagskabet. Bemærk modeller som hænger frit på væggen eller ned af loftet (frithængende). De medfølgende skorsten med de aflange ventilations huller skal monteres, så de bliver synlige efter installation. Luften vil nemlig recirkulere gennem disse huller.

UDSKIFTNING AF LAMPER

Belysningssystem 5 watt LED.

Afbryd enheden fra elektricitet. Advarsel! Sørg for, at pærerne er afkølet, før du rører ved dem. Udskift den gamle pære med en af samme type.

Emhætten er udstyret med et lyssystem baseret på LED-teknologi.

LED belysning holder op til 10 gange længere end konventionelle lamper og sparer 90 % strøm.

7 VEDLIGEHOLDELSE OG RENGØRING FORSIGTIG

Miljøbeskyttelse

Ved at sikre, at dette produkt bortskaffes korrekt, hjælper du med at forhindre mulige negative konsekvenser. Miljø- og sundhedsrisici, der kan opstå som følge af forkert håndtering af affald fra dette produkt.

Symbolet på produktet angiver, at dette produkt ikke kan behandles som husholdningsaffald.

Det afleveres til det relevante indsamlingssted til genbrug af elektrisk og elektronisk udstyr, som håndterer det i overensstemmelse med lokale miljøbestemmelser vedrørende bortskaffelse af affald.



SJ 3173-60 SR

SJ 3173-90 SR

INSTRUCTION MANUEL

Make the difference on your kitchen with our hoods.

Cooker hoods play an essential role in keeping your kitchen fresh, so you can always enjoy your cooking.

Thank you for buying this high quality hood from us.

Our policy is one of constant development and improvement. Strict accuracy of illustrations and specifications is not guaranteed. Before using the appliance for the first time, remove all packaging and protect with polythene film. This appliance has been designed for use as an extracting (air evacuation to the outside) or filtering (indoor air re-cycling) hood. Because of the complexity and weight of the appliance, it is recommended that the installation be carried out by specialist personnel. The manufacturer declines all responsibility for damage caused by improper or installation. Please read this handbook carefully and keep it for future reference.

CONTENTS

1 IMPORTANT SAFETY NOTICE

2 FEATURE

3 SAFETY WARNING

4 PRODUCT INTRODUCTION AND TECHNICAL INFORMATION

5 MOUNTING & INSTALLATION

6 PRODUCT USAGE

7 MAINTENANCE & CLEANING ATTENTION

1 IMPORTANT SAFETY NOTICE

Dear Customer, thank you for choosing our cooker hood.

This Instruction manual (IM) explains the proper installation and use of your cooker hood.

- Please read the instruction manual carefully before using even if you are familiar with the product.
- The manual should be kept in a safe place for future reference.
- The installation work must be undertaken by a qualified and competent fitter.
- The manufacturer disclaims all liability for any damage or injury caused as a result of not following instructions for installation contained in the following text.
- The cooker hood is used on 220/240v, 50-60 Hz
- Please note, that this manual may also apply to other models.

2 FEATURE

- The Cooker hood uses high quality materials and is made a a streamlined design.
- Equipped with a large power low noise electric motor it produces strong suction, low noise, non stick grease filter and easy to clean.

3 SAFETY WARNING

- The operating voltage is 220/240v
- Never let the children operate the cooker hood
- The cooker hood is for home use only, not suitable for industrial kitchens.
- Please ask the technical person to do the assembling
- The cooker hoods should be placed at a distance of 45-65cm from the cooking surface for the best effect.
- Do not try to use the cooker hood without the grease (aluminum) filters or if the filters are excessively greasy.
- Do not remove the filter while the hood is operating
- Do not leave frying pans unattended during use because overheated fats or oils might catch fire and the oil in the aluminum filter may ignite and cause fire.
- Never leave naked flames under the cooker hood.
- If cooker hood cleaning is not carried out periodically, in hood may occur burning risk
- The hood should be operate after putting pots or pans on the hobs.
- In order to clean the kitchen air well from smell, the hood should be operate also 15 minutes after cooking or frying is over.
- The cooker hood and its filter mesh should be clean regularly in order to keep in good working order
- Before cleaning, please switch the power off at the main supply
- Clean the cooker hood according to the instruction manual and keep the cooker hood from the danger of burning.
- If there is any fault with the appliance, please call the service department to arrange a service engineer.

4 PRODUCT INTRODUCTION AND TECHNICAL INFORMATION

- Ⓐ CHIMNEY CONNECTOR
- Ⓑ HOOD BODY
- Ⓒ CONTROL PANEL

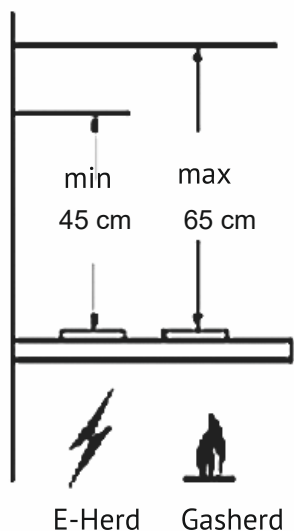
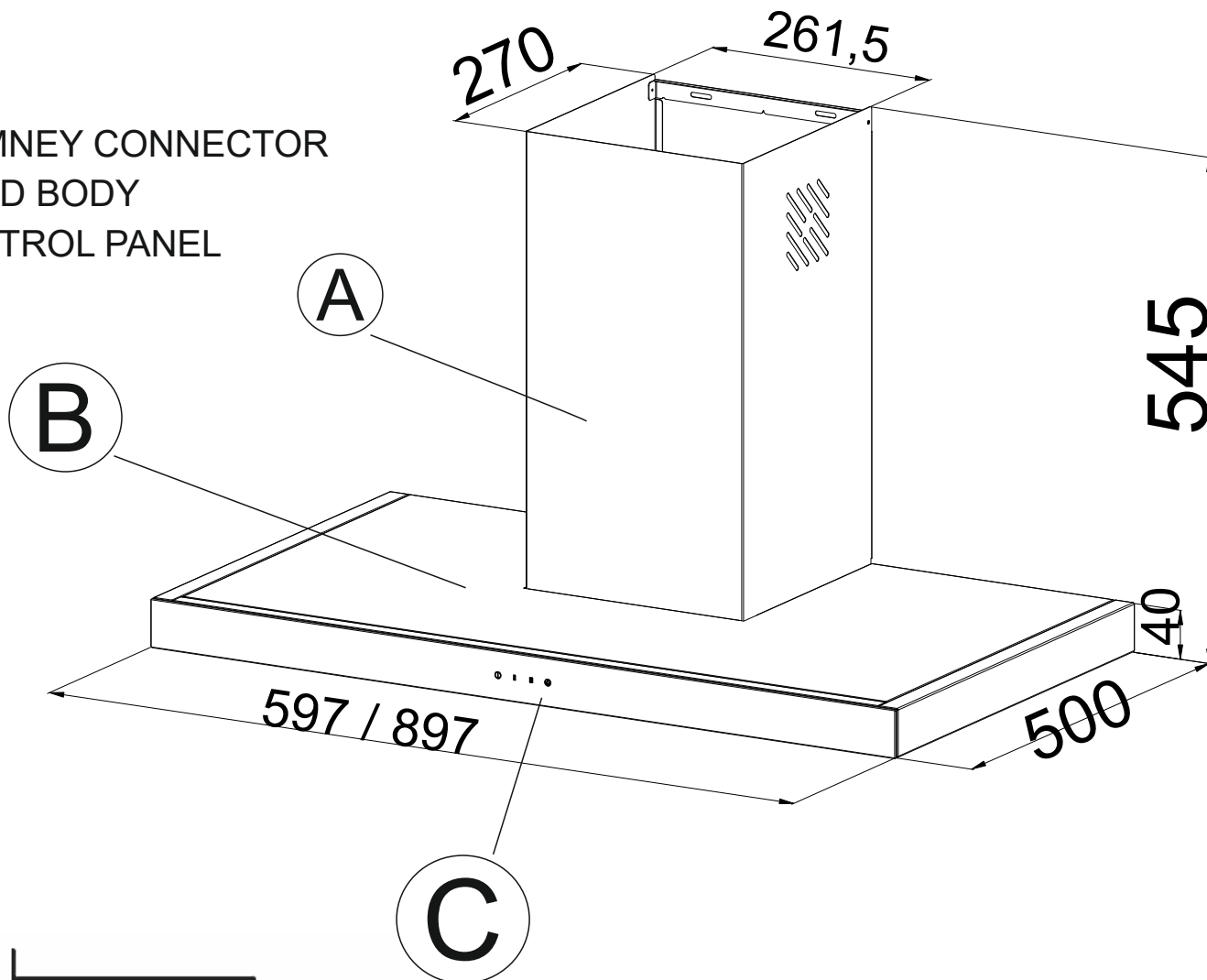

WIDTH	597/897 mm
DEPTH	500 mm
HEIGHT	545 mm
VOLTAGE	220-240V, 50-60 Hz
CAPACITY	750 m3/h
SPEED	3
MOTOR POWER	210 W
LIGHTING	2X2 W
AIR OUTPUT	150/120 mm

5 MOUNTING & INSTALLATION

- The cooker hoods should be placed at a distance of 45-65cm from the cooking surface for the best effect.
- The cooker hood is very heavy : hood handling and installation must be carried out by at least two persons.
- Before beginning installation, please follow below instruction :
- Check that the product purchased is of a suitable size for the chosen installation area.
- Remove the charcoal (*) filter/s f supplied ` This/these is/are to be mounted only if you want lo use the hood in the filtering version.
- Check (for transport reasons) that there is no other supplied material inside the hood (e.g. packets with screws (*), guarantees (*), etc.), eventually removing them and keeping them.
- If possible, disconnect and move freestanding or slide-in range from cabinet opening to provide easier access to rear wall/ceiling. Otherwise put a thick, protective covering over countertop, cooktop or range to protect from damage and debris. Select a flat surface for assembling the unit. Cover that surface with a protective covering and place all canopy hood parts and hardware in it.
- In addition check whether near the installation area of the hood (in the area accessible also with the hood mounted) an electric socket is available and it is possible to connect a fumes discharge device to the outside (only suction version).
- Carry out all the masonry work necessary (e.g. installation of an electric socket and/or a hole for the passage of the discharge tube). Expansion wall plugs are provided to secure the hood to most types of walls/ ceilings. However, a qualified technician must verify suitability of the materials in accordance with the type of wall/ceiling. The wall/ceiling must be strong enough to take the weight of the hood. Do not tile, grout or silicone this appliance to the wall, surface mounting only.

5 MOUNTING & INSTALLATION

Product position: Height between the bottom surface of your hood and the top surface of your hood
The stove/oven distance should be between 45 - 65 cm.





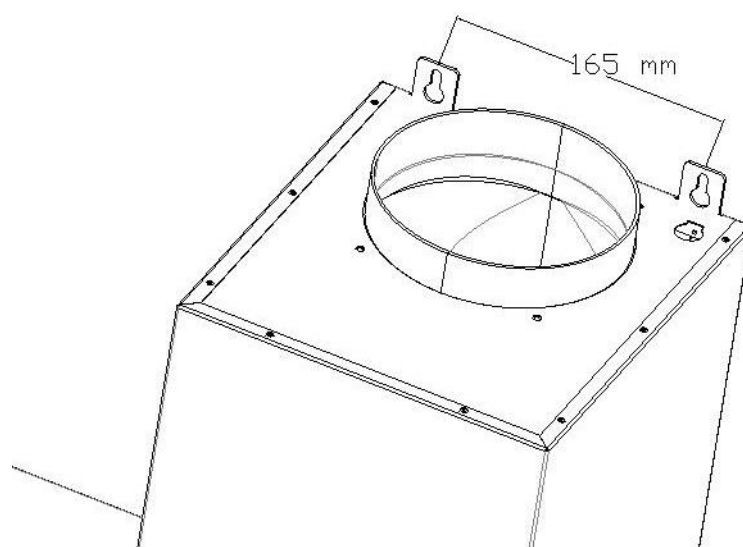
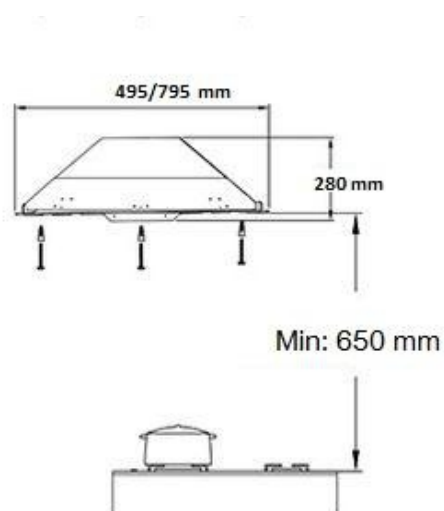

Preparations for assembly of the product: The following information is necessary to make your location suitable for your habitat.

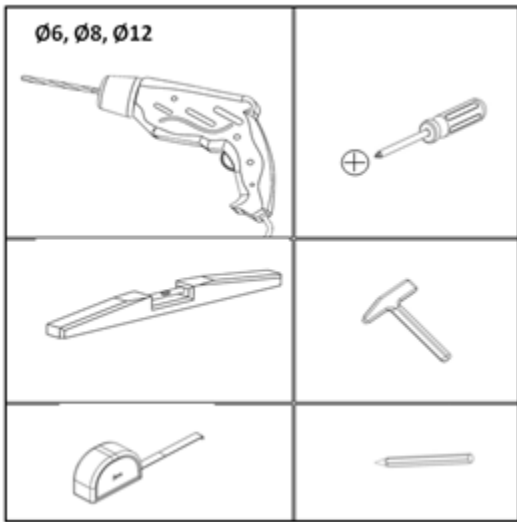
Mounting of the product in the kitchen cabinet: Fix the hood to wall with 2 dubels and screws.



5 MOUNTING & INSTALLATION



	Ø8x40	4x
	Ø5x40	4x
	Ø7	4x
	Ø3.9x19	6x
		1x
		1x
	120	1X

Aluminum pipe fitting: One end of the aluminum pipe is the plastic bacquet on the product; And the other end to the kitchen sink. Make sure that these two connectors are tight enough that they will not come out of place when the hood is operating at the highest speed. The diameter of plastic bacan on the product is 150 mm. If aluminum pipe with a diameter of 120 mm is to be used, it is necessary to install a plastic reducer from the packaging.

6 PRODUCT USAGE

- We recommend that the hood should be operate before any food is cooked. At the same time, we recommend that your product should be operate for 15 minutes after cooking.
- The effective performance of your hood depends on regular care.
- The lighting system is designed to be used during the cooking process. Please do not use it for a long time to general illumination of the room.

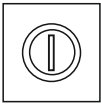
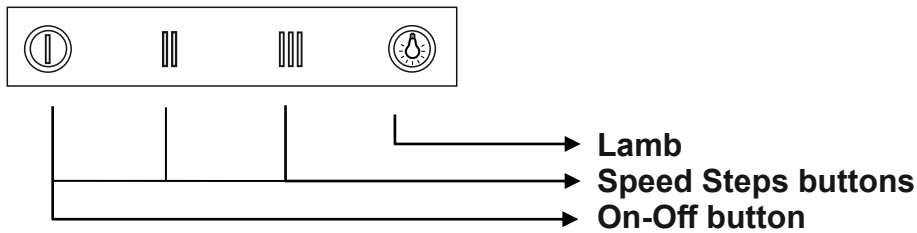

On-Off button: Touching this area will start working at the 1st speed level when you turn on the product. Press this field to turn off the product while it is running.



Lamb: Turns the light on and off.



Speed Steps button: The cycle phases are designated as 1, 2 and 3; You can therefore increase or decrease the speed with these buttons.

Timer: If you press the timer button while the aspirator is operating in any of the cycle stages, the aspirator will run for 15 minutes and will stop automatically after this time. When the automatic stop is activated, the speed indicator on the display will flash. Press the timer button again to deactivate the timer.

Filter Warning: When the cumulative motor ON time exceeds 30 hrs of operation an 'F' will be displayed, each time the motor starts, warning the user that the Grease Filter needs to be cleaned/replaced. When the cumulative motor ON time exceeds 300 hrs of operation a 'C' will be displayed, each time the motor starts, warning the user that the Carbon Filter needs to be cleaned/replaced. To reset the Grease Filter warning the user must press and hold the ▼ (-) button, while the motor is OFF, until an 'E' is displayed indicating that the Grease Filter timer has been reset. To reset the Carbon Filter warning the user must press and hold the ▲ (+) button, while the motor is OFF, until an 'E' is displayed indicating that the Carbon Filter timer has been reset.

7 MAINTENANCE & CLEANING ATTENTION

MAINTENANCE & CLEANING ATTENTION

Before performing any maintenance operation, isolate the hood from the electrical supply by switching off at the connector and removing the connector fuse. Or if the appliance has been connected through a plug and socket, then the plug must be removed from the socket.

The cooker hood should be cleaned regularly (at least with the same frequency with which you carry out maintenance of the fat filters) internally and externally. Clean using the cloth dampened with neutral liquid detergent. Do not use abrasive products.

To protect the main body from corrosion over a long period of time, the cooker hood should be cleaned with hot water plus non corrosive detergent every two months. Please do not use abrasive detergent for it will damage the body. Keep the motor and other spare parts free from water, as this will cause damage to the appliance.

DO NOT USE ALCOHOL!

If the plug or cord is damaged, please replace it with special soft cord.

ALUMINUM (GREASE) FILTER

Traps cooking grease particles. The grease filter must be cleaned once a month using non aggressive detergents, either by hand or in the dishwasher, which must be set to a low temperature and a short cycle. When washed in a dishwasher, the grease filter may discolour slightly, but this does not affect its filtering capacity. Please do not use the corrosive detergent on it. To remove the grease filter, pull the spring release handle. Charcoal filter (filter version only) It absorbs unpleasant odours caused by cooking.

CHARCOAL (CARBON) FILTER

The saturation of the charcoal filter occurs after more or less prolonged use, depending on the type of cooking and the regularity of cleaning of the grease filter. In any case it is necessary to replace the cartridge at least every four months. The charcoal filter may NOT be washed or regenerated. The carbon filter shouldn't be exposed to heat. Please don't tear open the fixed bar around the carbon filter.

CIRCULAR CARBON FILTER

Carbon filters are used only when the hood is not supported Keyed to the ventilation duct. Activated carbon filters have the ability to absorb odors until completely absorbed. Not subject regeneration or cleaning, should change at least every two months.

Apply one on each side as cover to both the shield grids of the motor impeller, then turn clockwise. For the disassembly, turn counter clockwise.

REPLACING LAMPS

The illumination system consists of 1x5 Led, Flush Lighting and etc. different types of Led Lighting. Disconnect the appliance from the electricity. **Warning!** Prior to touching the light bulbs ensure they are cooled down. Replace the old light bulb with the one of the same type as specified in the feature label or near the light lamp on the hood. The hood is equipped with a lighting system based on LED technology. The LEDs guarantee an optimum lighting, a duration up to 10 times as long as the traditional lamps and allow to save 90% electrical energy. For replacement, contact the technical service.

7 MAINTENANCE & CLEANING ATTENTION

Your contribution to protecting the environment

By ensuring this product is disposed of correctly, you will help prevent potential negative consequences for the environment and human health, which could otherwise be caused by inappropriate waste handling of this product. The symbol on the product indicates that this product may not be treated as household waste. Instead it shall be handed over to the applicable collection point for the recycling of electrical and electronic equipment. Disposal must be carried out in accordance with local environmental regulations for waste disposal. For more detailed information about treatment, recovery and recycling of this product, please contact your local city office, your household waste disposal service or the shop where you purchased the product.